

System Components



TILLER-HEAD TEMO 600

The tiller-head can be used on many applications in electric vehicles; for example, with pedestrian fork lift trucks, cleaning machines, burden carriers, etc.

The essential components of the tiller-head are the tiller-head-housing with the grips, various kinds of buttons, one belly button switch and a traction switch. We can offer different traction switches, which are designed for control systems from well-known manufacturers (Curtis, DMC, Dynamic Controls, PG Drives Technology, Sauer Danfoss, Sevcon and Zapi). The symbols are etched by a laser and consequently resistant against environmental influences.

- A lot of possible applications
- Stable tube handles
- Ergonomic handling
- Floating-mounted belly button switch
- Multi-function cover
- Connection for the tiller tube / pipe (at customer request)
- Buttons and switches freely configurable (in function, quantity and colour)
- Awarded with the IF Design Award 2005, Reddot Design Award 2005 and Materialica DESIGN AWARD 2005
- Manufactured in the WIT-procedure (plastic moulding with water injection and gas)

System Components

Assembly / Disassembly

The upper part and the lower part are joined through four socket screws. If you unscrew these four bolts, you could easily lift off the two parts. The mounting plate is screwed with three M8-bolts at the tiller head.

Connection Mounting Bracket

The tube and the mounting plate are not included in delivery.



Technical Specifications

Operation Elements

| | |
|-------------------------------|------------------------------------------------------------------------------------------------------------|
| Button/rocker switch/switches | Max. breaking capacity 48 V _{DC} / 1 A Min. breaking capacity 24 V _{DC} / 10 mA |
| Analogue switches | Max. breaking capacity 48 V _{DC} / 4 mA switching current Wiper current < 0.1 mA |
| Signal horn | Micro-switch NO Connector 2-pin |
| Optimum range of application | 10 mA / 5 V – 1.5 A / 24 V |
| Rabbit / turtle (optional) | Micro-switch NO Connector 2-pin |
| Optimum range of application | 5 mA / 3 V – 50 mA / 24 V |
| Traction switch | Diff. versions are possible (for different control systems) |
| Mounting bracket | Max. 40 x 70 mm |

Standard Colours

| | |
|------------------------------|----------------------|
| Operation elements (buttons) | RAL 2011 deep orange |
| Lower part with handle | RAL 9005 jet black |
| Cover top and under | RAL 7015 slate grey |
| Belly button switch | RAL 3000 flame red |
| Connectors | Molex Mini-Fit, Jr.™ |

Operating Conditions

| | |
|------------------------------|---------------------------------------------------------------------------|
| Operating temperature | -40°C to +85°C |
| Vibration test: | According to IEC 68-2-6 |
| Protection class (DIN 40050) | Tiller head IP 40 Operation elements and traction switch minimum IP 54 |

Special Design

- The operation elements and the grips are available in different standard colours. Special colours would be possible on request.
- Laser-marking of the operation elements
- It is possible to integrate a key switch, button, switch, display, keyboard or other applications in the underside of the multi-function cover.
- Protective shield for round tiller tubes

Dimensions [mm]

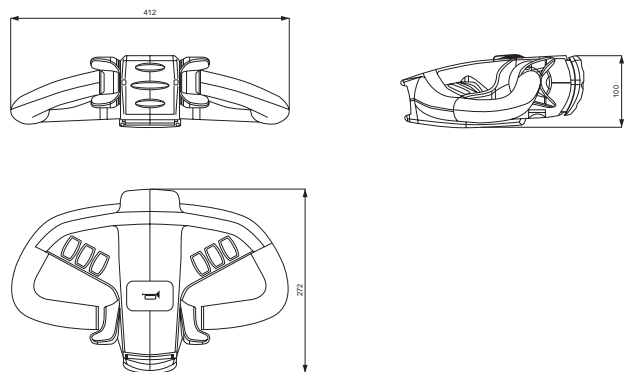

Required Details on Inquiries

- Number of buttons / rocker switches / switches / analogue switches
- Designation of the controller to find the right traction switch
- With or without multi-function cover
- With or without mounting plate
- With or without rabbit / turtle
- With or without key switch
- With or without special colours

Order Data

| Part No. | Description |
|---------------|-------------------------------------------|
| 3101-00060-XX | TEMO 600 will be configured user-specific |

Please complete the enclosed order-questionnaire with your desired specifications.

You could send it by fax to +49 (0) 7432.202-299 or by e-mail to info-stt@frei.de